



# HDBU Series

## Dynamic Braking Unit

### User Manual

---



V1.3 2018.11

## FOREWORD

Thank you for purchasing HDBU series dynamic braking unit manufactured by Shenzhen Hpmont Technology Co., Ltd.

HDBU series dynamic braking unit (hereinafter referred to as braking unit) are used with inverter to consume the feedback energy in the motor slowdown process and to achieve fast braking control.

This User Manual describes how to use the braking unit and its installation wiring, troubleshooting and daily maintenance etc.

Before using the product, please read through this User Manual carefully. In addition, please do not use this product until you have fully understood safety precautions.

Note:

- Preserve this Manual for future use.
- If you need the User Manual due to damage, loss or other reasons, please contact the regional distributor of our company or directly contact our company Technical Service Center.
- If you still have some problems during use, please contact our company Technical Service Center.
- Due to product upgrade or specification change, and for the purpose of improving convenience and accuracy of this manual, this manual's contents may be modified.
- Email address: **overseas\_1@hpmont.com**

## Version and Revision Records

**Time: 2018/11**

**Version: V1.3**

Revised chapter	Revised contents
	• Modify EMC information



# CONTENTS

Chapter 1 Safety Information and Precautions.....	1
Chapter 2 Product Information.....	2
2.1 Model.....	2
2.2 Product Selection.....	2
2.3 Nameplate.....	3
2.4 Part Name.....	3
2.5 Fuse Explanation.....	4
Chapter 3 Mechanical Installation.....	5
3.1 Installation Precautions.....	5
3.2 Requirement for the Installation Site.....	5
3.3 Installation Direction and Space Requirements.....	6
3.4 Dimensions and Mounting Size.....	7
Chapter 4 Electrical Installation.....	8
4.1 Wiring Requirements.....	8
4.2 Power Terminal Description.....	9
4.3 Control Terminal Description.....	10
4.3.1 Terminal Description.....	10
4.3.2 Indicator Description.....	11
4.3.3 SW1 Dial Switch Description.....	11
Chapter 5 Typical Application.....	12
5.1 Single Application.....	12
5.2 Two Braking Units for Parallel Application.....	13
5.3 Three Braking Units for Parallel Application.....	14
Chapter 6 Troubleshooting and Maintenance.....	15
6.1 Troubleshooting.....	15
6.2 Maintenance.....	16



## Chapter 1 Safety Information and Precautions

### Safety Definition

 <b>Danger</b>
<b>Danger:</b> A Danger contains information which is critical for avoiding safety hazard.
 <b>Warning</b>
<b>Warning:</b> A Warning contains information which is essential for avoiding a risk of damage to product or other equipments.
<u>Note</u>
<b>Note:</b> A Note contains information which helps to ensure correct operation of the product.

### Precautions

Before delivering, this product has been strictly checked and reliably packaged. Due to handling, loading and unloading in transit, it may cause damage. Therefore, after open the package please check product integrity carefully:

Check items	Check methods
Whether the product is in agreement with your ordering information	Check the nameplate on the right side of product
Whether there is damage to parts or damaged	Check the overall appearance, check if there is damage in transit
If there is loose screws or other fasten parts	If necessary, use the screwdriver to check
Whether the manual intact	Check the manual

If has lacked, please contact manufacturer.

## Chapter 2 Product Information

### 2.1 Model

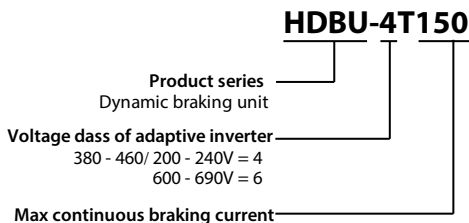

### 2.2 Product Selection

Table 2-1 HDBU specifications

Model	DC input voltage (VDC)	Max continuous braking current (A)	Braking resistance range ( $\Omega$ )	Voltage class of adaptive inverter (VAC)
HDBU-4T050	250 - 800	50	$\geq 15$	380 - 460 / 200 - 240
HDBU-4T075		75	$\geq 10$	
HDBU-4T100		100	$\geq 7$	
HDBU-4T150	250 - 800	150	$\geq 5$	380 - 460 / 200 - 240
HDBU-4T250		250	$\geq 3$	
HDBU-6T150	850 - 1200	150	$\geq 8$	500 - 690
HDBU-6T250		250	$\geq 5$	

Table 2-2 Selection for the braking unit

Inverter		Braking unit		
Voltage class	Power class	Model	Number	Configuration
380 - 460 VAC	11 - 22kW	HDBU-4T050	1	Single
380 - 460 VAC	30 - 37kW	HDBU-4T075	1	Single
380 - 460 VAC	45 - 55kW	HDBU-4T100	1	Single
380 - 460 VAC	75 - 110kW	HDBU-4T150	1	Single
380 - 460 VAC	132 - 200kW	HDBU-4T250	1	Single
380 - 460 VAC	220 - 315kW	HDBU-4T250	2	Parallel
380 - 460 VAC	355 - 400kW	HDBU-4T250	3	Parallel
600 - 690 VAC	75 - 110kW	HDBU-6T150	1	Single
600 - 690 VAC	132 - 220kW	HDBU-6T250	1	Single
600 - 690 VAC	250 - 400kW	HDBU-6T250	2	Parallel

### 2.3 Nameplate

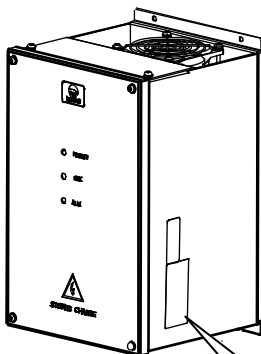

<b>hpmont</b>	
Product model	MODEL: HDBU-4T150
Input voltage	INPUT: 250-800VDC
Braking current	OUTPUT: 0-150A
Serial number	
<b>Shenzhen Hpmont Technology Co., Ltd</b>	

### 2.4 Part Name

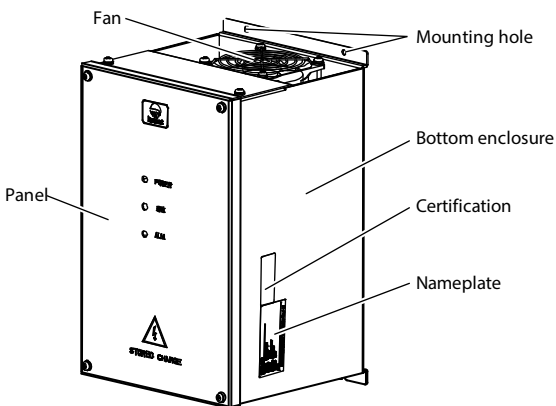



## 2.5 Fuse Explanation

The DC bus input side of braking unit is built-in fuse whose location is shown as Figure 2-1.

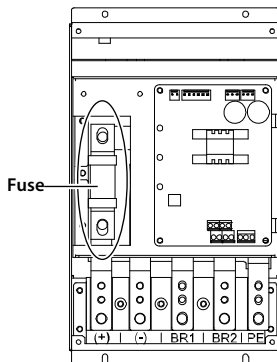



Figure 2-1 Location of fuse

If the braking unit is damaged by accident, this fuse can break off the electrical connection between braking unit and inverter's DC bus so as to avoid inverter damage.

When the fuse is damaged, please use another fuse which is the same as the damaged one, such as the same brand and model. If have any question, please contact us or our suppliers.

## Chapter 3 Mechanical Installation

### 3.1 Installation Precautions

 <b>Danger</b>
<ul style="list-style-type: none"> <li>• Do not install if the braking unit is incomplete or impaired.</li> <li>• Please see the size and weight to take appropriate tools for handling, avoid harming from sharp edges or injured by a dropped controller</li> <li>• Make sure that the braking unit is far from the explosive and combustibile things.</li> <li>• Only when the power supply is completely cut-off 10 minutes later can you do the wiring job.</li> </ul>
 <b>Warning</b>
<ul style="list-style-type: none"> <li>• It is required not only carry the keypad and the cover but also the inverter bottom enclosure.</li> <li>• Do not play metal into the braking unit when installing.</li> </ul>

### 3.2 Requirement for the Installation Site

Ensure the installation site meeting the following requirements:

- Do not install at the direct sunlight, moisture, water droplet location;
- Do not install at the combustible, explosive, corrosive gas and liquid location;
- Do not install at the oily dust, fiber and metal powder location;
- Be vertical installation on fire-retardant material with a strong support;
- Make sure adequate cooling space for the braking unit so as to keep the ambient temperature among -10 - +40°C;
- Install at where the vibration is 3.5m/s<sup>2</sup> in 2 - 9Hz, 10m/s<sup>2</sup> in 9 - 200Hz (IEC60721-3-3);
- Install at where the humidity is less than 95%RH and non-condensing location;
- Protection level of HD30 is IP20 and pollution level is 2 (Dry, non-conducting dust pollution).

**Note:**

1. It needs derating use if the braking unit operation temperature exceeds 40°C. The derating value of braking unit shall be 2% for each degree centigrade. Max. allowed temperature is 50 °C.
2. Keep ambient temperature among -10 - +40 °C. It can improve the braking unit operation performance if install at the location with good ventilation or cooling devices (do not install the braking resistor mounted in proximity to the inlet of the braking unit).

### 3.3 Installation Direction and Space Requirements

When install several braking unit, it should consider the heat dissipation of air flow.

To achieve good cooling efficiency, install the barking unit perpendicularly wall-mounted side by side and always provide the following space to allow normal heat dissipation. Just as shown in Figure 3-1.

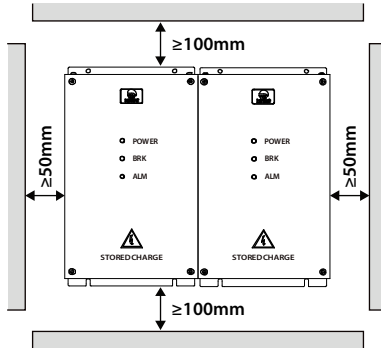

Figure 3-1 Installation of braking unit

As show in Figure 3-2, the gap between two units must over 300mm when place one unit on top of another one.

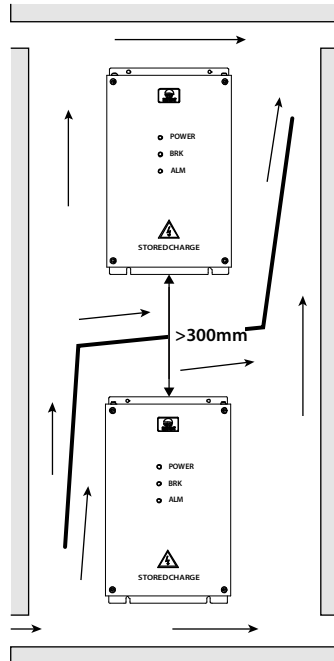

Figure 3-2 Installation of several braking units

### 3.4 Dimensions and Weight

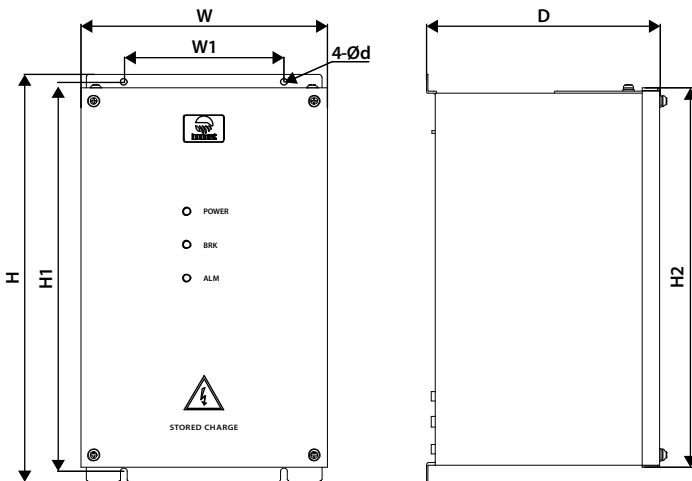

Figure 3-3 HDBU dimensions

Table 3-1 HDBU dimensions and weight

Model	Dimension (mm)			Mounting size (mm)				GW (kg)
	W	H	D	W1	H1	H2	d	
HDBU-4T050	138	190	140	120	180	176	4.5	3
HDBU-4T075								
HDBU-4T100								
HDBU-4T150	185	305	180	120	292	284	5	8
HDBU-4T250								
HDBU-6T150								
HDBU-6T250								

## Chapter 4 Electrical Installation



**Danger**

- Only qualified electrical engineer can perform wiring job.
- The cable on power terminal should have no metal parts exposed in air.
- Do not dismantle HDBU or do wiring operation until the power is cut-off for more than 10 minutes, the internal charge indicator of HDBU is off and the voltage between (+) and (-) of the main circuit terminals is below 36V.
- The brake unit will produce large leakage current. The GND terminal of unit must be grounded firmly. Two independent ground wires can guarantee reliable grounding.
- Do not touch the wire terminals of HDBU when it is live. The main circuit terminals are neither allowed connecting to the enclosure nor short-circuiting.



**Warning**

- Make sure the inverter's power supply voltage is the same as the braking unit's rated voltage.
- Do not do dielectric strength test on the brake unit.
- Do wiring connection of the braking resistor or the braking unit according to the wiring figure. Do not connect the braking resistor to DC terminals (+) and (-) of the braking unit.
- Make sure that the terminals are fixed tightly.
- Do not play screws, washers and metal bars etc. metal into the braking unit when installing.
- Do not mount the braking unit at the water pipe where may have a water droplet splash.
- Do not supply the damage or parts of insufficiency of the braking unit with power.

### 4.1 Wiring Requirements

1	For the two power terminals' wiring between the inverter and the braking unit, it is suggested to use the red and the black of 600V voltage level cable, to prevent the DC bus terminal wiring error.
2	For the wiring between the braking unit and the braking resistor, please use the 600V voltage level of high temperature cable.
3	The two lines should be closed and used twisted pair when connect the inverter with the braking unit so as to reduce the current loop. It suggests that the length of wiring should be less than 5m and not exceed 10m.
4	The interval distance between the control terminal wiring and the power terminal wiring should be greater than 0.3m so as to reduce the interference to control terminal signal.

### 4.2 Power Terminal Description

Power terminals layout as shown in Figure 4-1 and Figure 4-2.

Power terminals description as shown in Table 4-1.

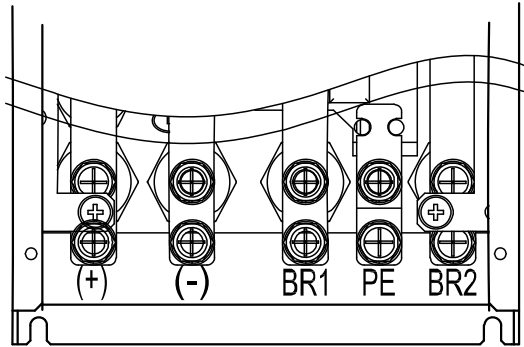

Figure 4-1 Power terminal (HDBU-4T050 / -4T075 / -4T100)

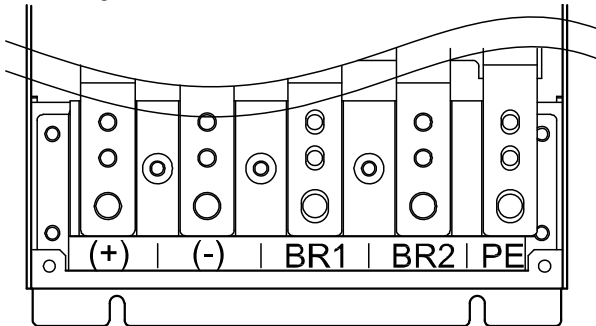

Figure 4-2 Power terminal (HDBU-4T150 / -4T250 / -6T150 / -6T250)

Table 4-1 Power terminal function description of braking unit

Terminal	Description	
(+), (-)	DC bus input terminal	Respectively connect to the inverter DC bus (+) and (-)
BR1, BR2	Connect to the braking resistor	Connect to the braking resistor
PE	Terminal of protective earth	Connect to the protective earth

### 4.3 Control Terminal Description

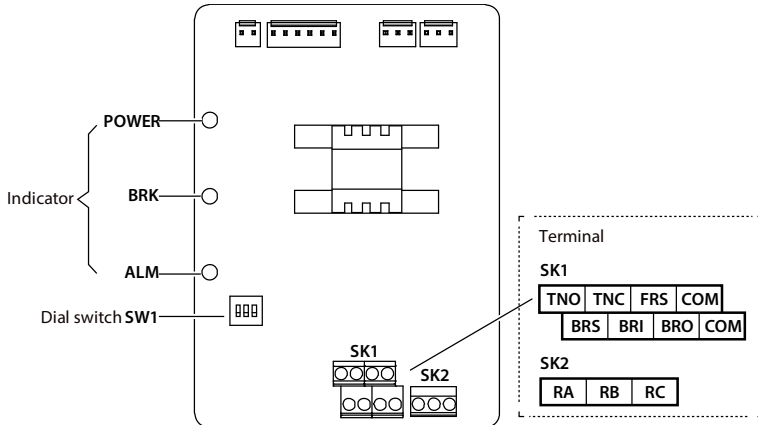

Figure 4-3 Control board

#### 4.3.1 Terminal Description

Table 4-2 Control terminal description

Terminal		Description	
SK1	TNO	Normally open terminal for braking resistor's overheated protection	Normally-open temperature switch for overheated protection input. This function is enabled when short connected with COM
	TNC	Normally closed terminal for braking resistor's overheated protection	Normally-closed temperature switch for overheated protection input. This function is enabled when disconnected with COM <i>Note: It need connect the TNO to the COM at the same time</i>
	FRS	Fault reset terminal	When the braking unit is faulty, connect the FRS to the COM to achieve fault reset function
	BRS	Terminal for selective braking command source	<ul style="list-style-type: none"> <li>When the BRS terminal is suspension, the braking unit's braking command is decided by the DC bus input voltage automatic detection value</li> <li>When the BRS and the COM are short connected, the braking unit's braking command is decided by the BRI terminal</li> </ul>
	BRI	Input terminal for braking command	When the BRI and the COM are short connected, the braking unit starts to operate
	BRO	Output terminal for braking state	When the braking unit is at the braking state, this terminal output is enabled
	COM	Signal ground	Signal reference ground
SK2	RA/RB/RC	Fault output terminal	Relay of 1c contact output Contact rating: 250VAC /3A or 30VDC /1A <ul style="list-style-type: none"> <li>RC-RA: Normally open contact, RC-RB: Normally closed contact</li> </ul>

### 4.3.2 Indicator Description

Table 4-3 Indicator description

Indicator		Description
POWER	Braking unit power-on indicator	On: The braking unit is at power-on state Off: The braking unit is not at power-on state
BRK	Braking unit's state indicator	On: The braking unit is at braking state Off: The braking unit is at standby state
ALM	Braking unit's fault alarm state indicator	On: The braking unit is faulty Off: The braking unit is not faulty





### 4.3.3 SW1 Dial Switch Description

According to the different power supply voltage of adaptive inverter, it need set the braking unit's braking voltage threshold via the SW1 dial switch.

To set the dial switch, it should be under the braking unit power-off condition.



The relation between the braking voltage threshold and the dial switch is shown as Table 4-4.

Table 4-4 Set the voltage

Product model	Power supply voltage of adaptive inverter (VAC)	DC voltage for braking action (VDC)	SW1 switch setting
HDBU-4T050 HDBU-4T075 HDBU-4T100 HDBU-4T150 HDBU-4T250	200 - 240	380	
		690	
	380 - 460	750	
HDBU-6T150 HDBU-6T250	600 - 690	1190	



## Chapter 5 Typical Application

 <b>Danger</b>
<ul style="list-style-type: none"> <li>Only when the braking terminal cover has been fitted can you switch on AC power source. Do not remove the cover after power is switched on.</li> </ul>
 <b>Warning</b>
<ul style="list-style-type: none"> <li>Do not check or detect the signal during the braking unit operation.</li> <li>Do not touch the energy-consumption braking resistor due to the high temperature.</li> </ul>

### 5.1 Single Application

According to Figure 5-1, connect the inverter, braking unit and braking resistor when use one braking unit. And according to the inverter's voltage class in Table 4-4, set the braking voltage threshold of braking unit.

The braking resistor selection cannot exceed the braking unit output capacity range. Please refer to Table 2-1 for proper braking resistor.

Due to the braking resistor of large power consumption, it is suggested that over-temperature protective switch should be mounted to achieve overheated protection for the braking resistor.

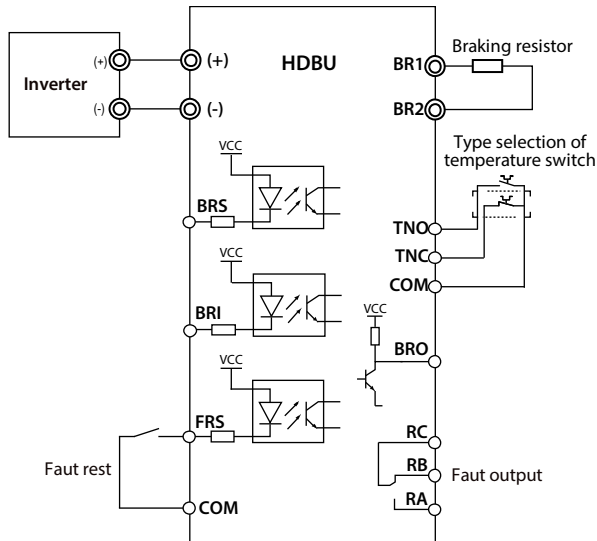

Figure 5-1 Single application connection

## 5.2 Two Braking Units for Parallel Application

If the output power of one brake unit can't meet field needs, we can use two brake units in parallel for increasing power. Wiring diagram as shown in Figure 5-2.

Set one brake unit as the master, set another one as the slave. The slave unit will automatically track the master for synchronized working.

- Connect the BRO (braking state output terminal) of master brake unit with the BRI (braking state input terminal) of slave brake unit.
- Connect the BRS (braking command source selection terminal) of slave with the COM (signal ground terminal).
- Connect the COM of master together with the COM of slave.

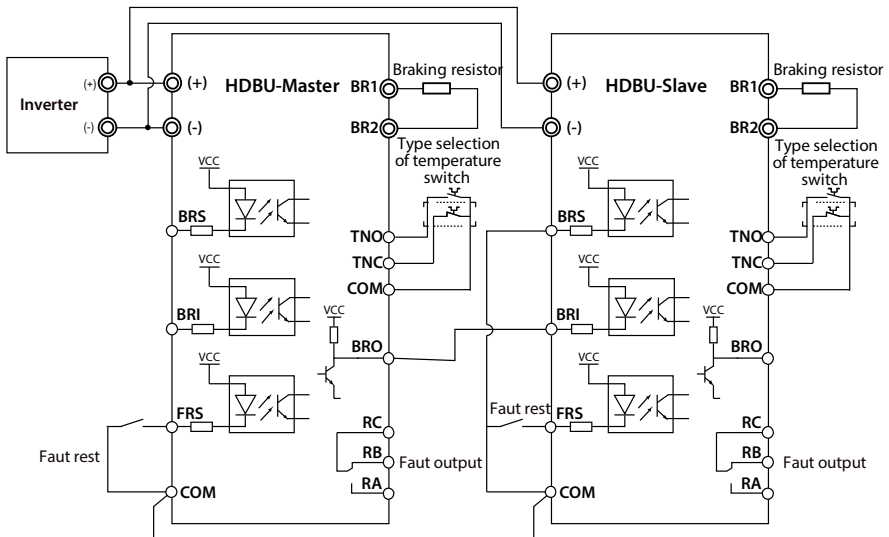

Figure 5-2 Two braking units for parallel application

### 5.3 Three Braking Units for Parallel Application

The wiring of three parallel brake units as shown in Figure 5-3.

Set one unit as the master, the other two units as the slave.

The two slave will automatically track the master for synchronized working.

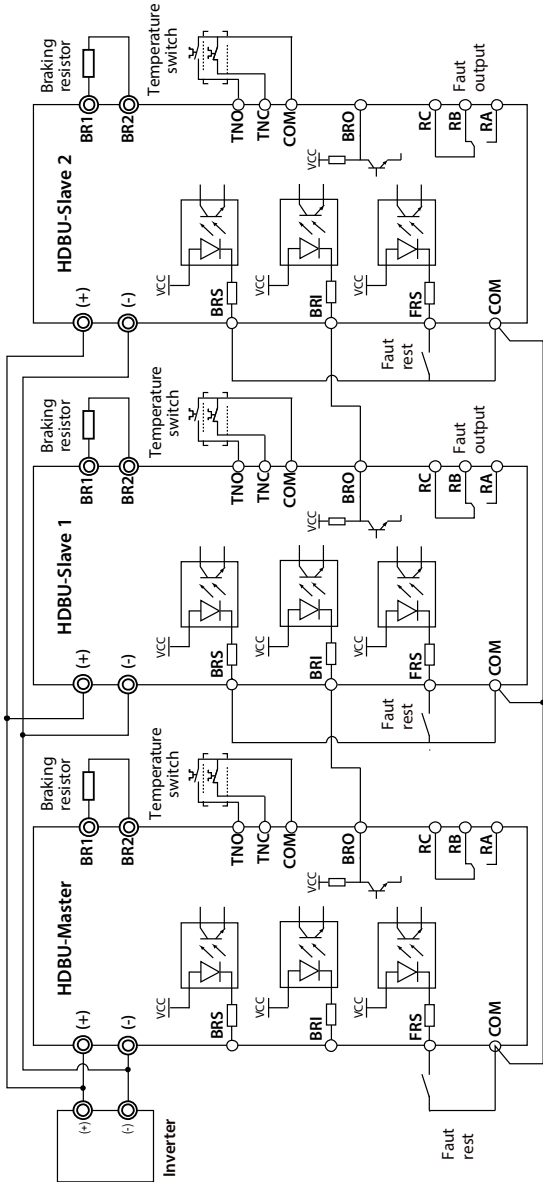

Figure 5-3 Three braking units for parallel application

## Chapter 6 Troubleshooting and Maintenance

### 6.1 Troubleshooting

When fault alarm occurs, please take proper action according to the Table 6-1.

Table 6-1 Fault alarm description and counter-measures

Fault	Fault reasons	Counter-measures
Overvoltage at inverter braking	<ul style="list-style-type: none"> <li>The braking resistor value is too big</li> <li>The inverter preset deceleration time is too short</li> </ul>	<ul style="list-style-type: none"> <li>Decrease the braking resistor value</li> <li>Properly increase the deceleration time</li> </ul>
Braking unit fault	<ul style="list-style-type: none"> <li>The heatsink temperature is too high</li> <li>The power module of braking unit is faulty</li> </ul>	<ul style="list-style-type: none"> <li>Please check the fan or change the work environment of braking unit</li> <li>Please contact the manufacture</li> </ul>
Braking unit does not operate all the time, and no fault is displayed	<ul style="list-style-type: none"> <li>The internal fuse has been fused</li> <li>The external locked signal is enabled</li> <li>The inverter's deceleration time is too long, which does not meet the braking working conditions</li> </ul>	<ul style="list-style-type: none"> <li>Change the fuse</li> <li>Please relieve the external locked signal</li> <li>Please decrease the inverter's deceleration time</li> </ul>
Braking resistor overheated protection	<ul style="list-style-type: none"> <li>The braking resistor power is too small</li> <li>The heat dissipation condition of braking resistor is too bad</li> <li>The braking unit internal over-temperature protection circuit is faulty</li> </ul>	<ul style="list-style-type: none"> <li>Please select larger power braking resistor</li> <li>Improve the braking resistor working environment</li> <li>Please contact the manufacture</li> </ul>

## 6.2 Maintenance



**Danger**

- Only a trained and qualified professional person can maintain the braking unit.
- Maintenance personnel should take off all metal jewellery before carrying out maintenance or internal measurements in braking unit. Suitable clothes and tools must be used.
- High voltage still exists at the internal when the braking unit is powered up or running.
- Checking and maintaining can only be done after braking unit's AC power is cut off. And wait for at least 10 minutes if maintain the cover.



**Warning**

- For the braking unit stored for more than 2 years, please use voltage regulator to increase the input voltage gradually.
- Do not leave metal parts like screws or pads inside the braking unit.
- Do not make modification on the inside of braking unit without instruction from the supplier.
- There are IC components inside the braking unit, which are sensitive to static electricity. Directly touch the components on the PCB board is forbidden.

### Daily Maintenance

Some unexpected accidents may occur during operation.

Therefore you should maintain the braking unit conditions according to the Table 6-2, record the operation data, and investigate problems immediately.

**Table 6-2 Daily checking items**

Items	Content	Criteria
Operating environment	Temperature and humidity	-10 - +40 °C, derating at 40 - 50 °C
	Dust and water dripping	No water dripping
	Gas	No strange smell
Braking unit	Oscillation and heating	Stable oscillation and proper temperature
	Noise	No abnormal sound

### Periodical Maintenance

Customer should check the braking unit in short time or every 3 to 6 months according to the actual environment so as to avoid hidden problems and make sure the braking unit runs well for a long time.

General Inspection:

- Check whether the screws of control terminals are loose. If so, tighten them with a screw driver;
  - Check whether the main circuit terminals are properly connected; whether the mains cables are over heated;
  - Check whether the power cables and control cables are damaged, especially check for any wear on the cable tube;
  - Check whether the insulating tapes around the cable lugs are stripped, and for signs of overheating near terminations.
- 

#### **Note:**

1. *Dielectric strength test of the controller has already been conducted in the factory. Do not do the test again. Otherwise, the braking unit might be damaged.*
  2. *If insulation test to the motor is necessary, it should be done after the input terminals U/V/W of motor have been detached from HDBU. Otherwise, HDBU will be damaged.*
  3. *For controllers that have been stored for a long time, they must be powered up every 2 years. When supplying AC power to the controller, use a voltage regulator to gradually raise the input voltage to rated input voltage at least 5 hours.*
- 

### Replacing Damaged Parts

The easily damaged component is the cooling fan. The lifetime depends largely on the application environment and preservation. The user can decide the time when the components should be replaced according to their service time.

Generally, due to the wear of bearing and aging of the fan vanes, the life of fan is 60,000 hours.

**Criteria:** After the braking unit is switched off, check if the abnormal conditions such as crack existing on fan vanes and other parts. When the braking unit is switched on, check if braking unit running is normal, and check if there is any abnormal oscillation.

### Unwanted Braking Unit Disposal

When disposing the braking unit, please pay attention to the following factors:

- The capacitors may explode if they are burnt.
- Poisonous gas may be generated when the plastic parts like front covers are burnt.
- Disposing method: Please dispose unwanted braking unit as industrial waste.